

P99 Pressure Reducing Regulator

Applications

- City / District gate operation
- Commercial buildings
- Boilers, furnace, oven
- Plant air service

Features

- 5 Pilot choices for low to extra high pressure
- Up to 1,000 psi inlet when fitted with a P39 reducing regulator
- Loading pressure bleeds downstream – no atmospheric relief

Operations

- Double diaphragm pilot providing quick response and high accuracy requires less droop than a direct operated regulator to obtain the same pressure difference.
- Pilots assemblies can be exchanged in the field from high to low pressure.
- Seat selections include an elastomer seat disk against a sharp edge orifice or an elastomer O-ring against a flat orifice.
- The O-ring against a flat orifice should be used in all applications with 250 psi and above inlet pressure and when heavy main springs are used.



P99 Specifications

P99 Specifications		
Pilot Versions	L	2" to 20 PSIG
	LD	Narrower proportional band than L
	LE	Broader proportional band than L
	H	10 to 65 PSIG
	HP	35 to 100 PSIG
Max Pilot Pressure	LD	160 PSIG
	L, LE, H	400 PSIG
	HP	600 PSIG
Temperature Ratings		
Nitrile, Neoprene	-20° to 180° F	-29° to 82° C
Fluorocarbon	0 to 300°F	-18° to 149° C
Weight Approximate		
	115 lbs.	52.2 kg

P99 Materials of Construction

P99 Main Regulator	
Body	Ductile Iron / WCB Steel
Spring Case	Ductile Iron
Upper and Lower Casing	Ductile Iron
Main Spring	Steel
Diaphragm	Nitrile
Diaphragm Plate	Steel
P99 Pilot Regulator	
Body	Ductile Iron
Spring Case	Ductile Iron
Casings	Ductile Iron
Diaphragms	Nitrile
Orifices	Stainless Steel / Brass
Springs	Steel
Bleed Valve	Stainless Steel
Tubing	Copper / Stainless Steel
Fittings	Brass / Stainless Steel

P99 Maximum Inlet, Pressure Drop and Differential Pressures

Max allowable inlet pressure / drop PSIG / BAR	Min differential for full stroke PSIG / BAR	Recommended disk material	Max Orifice Size	Notes
25 / 1.7	0.75 / 0.05	Nitrile or Fluorocarbon Disk	1-1/8"	Can use 1/2" through 1-1/8"
50 / 3.4	1.5 / 0.10	Neoprene or Fluorocarbon Disc	1-1/8"	Can use 1/2" through 1-1/8"
150 / 10.3	3 / 0.21	Nitrile, Neoprene or Fluorocarbon	1-1/8"	Can use 1/2" through 1-1/8"
250 / 17.2	3 / 0.21	Neoprene or Fluorocarbon O-ring	7/8"	7/8" and 1 1/8" only sizes for O-ring seat
300 / 20.7	10 / 0.69	Nylon Disk, Nitrile O-ring	1-1/8"	1-1/8" only available size for 300 inlet pressure
400 / 27.6	10 / 0.69	Nylon Disk	7/8"	7/8" and 1-1/8" only sizes for O-ring seat
1000 / 69.0	10 / 0.69	Nylon Disk	1/2"	1/2" only available orifice for 1000 inlet

Note: When choosing an O-ring seat and flat orifice, only the 7/8" and 1-1/8" orifice can be used

P99 Outlet Pressure Ranges

Pilot Type	Maximum Pilot Supply Pressure		Outlet (Control) Pressure Ranges		Pilot Control Spring					
					Part Number	Color Code	Wire Diameter		Free Length	
	PSIG	BAR	PSIG	BAR			Inches	mm	Inches	mm
LD	160	11.0	3 to 12 inches WC ⁽¹⁾	7 to 30 mBAR ⁽¹⁾	655-734-010	Unpainted	0.080	2.03	3.00	76.2
L	400	27.6	0.25 to 2	0.02 to 0.14	655-734-002	Red	0.109	2.77	2.75	69.9
LD	160	11.0	1 to 5	0.07 to 0.35	655-734-007	Yellow	0.142	3.61	2.75	69.9
			2 to 10	0.14 to 0.69	655-734-003	Blue	0.172	4.37	2.88	73.2
LE	400	27.6	5 to 15	0.35 to 1.0	655-734-008	Brown	0.187	4.75	3.03	77.0
			10 to 20	0.69 to 1.4	655-734-009	Green	0.207	5.26	3.13	79.5
H	400	27.6	10 to 65	0.69 to 4.5	655-659-003	Green stripe	0.363	9.22	6.00	152
HP	600	41.4	35 to 100	2.4 to 6.9	655-734-012	Blue	0.200	5.08	1.69	42.3

1. Type LD pilot only.

P99 Approximate Proportional Bands

Pilot Type	Pilot Control Spring						Proportional Bands	
	Part Number	Color Code	Wire Diameter		Free Length		WC / PSI	mBAR
			Inches	mm	Inches	mm		
LD	655-734-010	Unpainted	0.080	2.03	3.25	82.6	0.1 to 0.5 WC	0.25 to 1
L	655-734-002	Red	0.109	2.77	2.75	69.9	1 to 2 WC	2 to 5
LD		Red	0.109	2.77	2.75	69.9	0.25 to 1 WC	0.62 to 2
LE		Red	0.109	2.77	2.75	69.9	5 to 8 WC	12 to 20
L, LD, and LE	655-734-007	Yellow	0.142	3.61	2.75	69.9	0.1 to 0.3 PSI	6.9 to 21
	655-734-003	Blue	0.172	4.37	2.88	73.2		
	655-734-008	Brown	0.187	4.75	2.88	73.2		
	655-734-009	Green	0.207	5.26	3.13	79.5		
H	655-659-003	Green Stripe	0.363	9.22	6.00	152.4	0.1 to 0.3 PSI	6.9 to 21
HP	655-734-012	Blue	0.209	5.08	1.69	42.3	1 to 2 PSI	68.9 to 137.8

P99 Orifice Sizes and Flow and Sizing Coefficients

Trim Construction	Orifice Size		FOR RELIEF SIZING WIDE-OPEN C _g	REGULATING C _g	C ₁	K _m	IEC Sizing Coefficients		
	Inches	mm					X _T	F _D	F _L
Restricted capacity trim, Straight bore – Elastomer disk seat only	1/2	3	200	155	35	0.79	0.78	0.50	0.89
	5/8	16	300	216					
	3/4	19	425	330					
Full capacity trim, Elastomer disk, or O-ring seats	7/8 1-1/8	22 29	550 850	408 680					

P99 Capacities of Type 99 Regulators (Full Capacity)



Orifice Size		Inlet Pressure		Capacities in Thousands of SCFH / Nm³/h of 0.6 Specific Gravity Natural Gas ⁽²⁾																									
				Outlet Pressure, PSIG (BAR)																									
Inches	mm	PSIG	BAR	15 (1.0)		20 (1.4)		25 (1.7)		30 (2.1)		35 (2.4)		40 (2.8)		45 (3.1)		50 (3.5)		60 (4.1)		75 (5.2)		100 (6.9)					
				SCFH	Nm³/h	SCFH	Nm³/h	SCFH	Nm³/h	SCFH	Nm³/h	SCFH	Nm³/h	SCFH	Nm³/h	SCFH	Nm³/h	SCFH	Nm³/h	SCFH	Nm³/h	SCFH	Nm³/h	SCFH	Nm³/h	SCFH	Nm³/h		
7/8	22	20	1.4	10.8	0.3																								
		25	1.7	16.2	0.4	12	0.3																						
		30	2.1	20	0.5	17	0.5	12.5	0.3																				
		35	2.4	24	0.6	21	0.6	18	0.5	13	0.3																		
		40	2.8	28	0.8	26	0.7	23	0.6	19	0.5	14.4	0.4																
		50	3.4	34	0.9	34	0.9	31	0.8	28	0.8	25	0.7	21	0.6	15.5	0.4												
		60	4.1	42	1.1	42	1.1	42	1.1	37	1.0	35	0.9	30	0.8	27	0.7	23	0.6										
		75	5.2	47	1.3	47	1.3	47	1.3	47	1.3	47	1.3	45	1.2	41	1.1	37	1.0	30	0.8								
		100	6.9	59	1.6	59	1.6	59	1.6	59	1.6	59	1.6	59	1.6	59	1.6	59	1.6	53	1.4	44	1.2						
		125	8.6	73	2.0	73	2.0	73	2.0	73	2.0	73	2.0	73	2.0	73	2.0	73	2.0	73	2.0	66	1.8	48	1.3				
		150	10.3	86	2.3	86	2.3	86	2.3	86	2.3	86	2.3	86	2.3	86	2.3	86	2.3	86	2.3	86	2.3	86	2.3	72	1.9		
		175	12.1	96	2.6	96	2.6	96	2.6	96	2.6	96	2.6	96	2.6	96	2.6	96	2.6	96	2.6	96	2.6	96	2.6	93	2.5		
		200	13.8	108	2.9	108	2.9	108	2.9	108	2.9	108	2.9	108	2.9	108	2.9	108	2.9	108	2.9	108	2.9	108	2.9	108	2.9		
		225	15.5	123	3.3	123	3.3	123	3.3	123	3.3	123	3.3	123	3.3	123	3.3	123	3.3	123	3.3	123	3.3	123	3.3	123	3.3		
		250	17.2	132	3.5	132	3.5	132	3.5	132	3.5	132	3.5	132	3.5	132	3.5	132	3.5	132	3.5	132	3.5	132	3.5	132	3.5		
		300	20.7	162	4.3	162	4.3	162	4.3	162	4.3	162	4.3	162	4.3	162	4.3	162	4.3	162	4.3	162	4.3	162	4.3	162	4.3		
350	24.1	188	5.0	188	5.0	188	5.0	188	5.0	188	5.0	188	5.0	188	5.0	188	5.0	188	5.0	188	5.0	188	5.0	188	5.0				
400	27.6	215	5.8	215	5.8	215	5.8	215	5.8	215	5.8	215	5.8	215	5.8	215	5.8	215	5.8	215	5.8	215	5.8	215	5.8				
1-1/8	29	20	1.4	18	0.5																								
		25	1.7	27	0.7	20	0.5																						
		30	2.1	34	0.9	28	0.8	21	0.6																				
		35	2.4	40	1.1	35	0.9	30	0.8	22	0.6																		
		40	2.8	47	1.3	43	1.2	38	1.0	32	0.9	24	0.6																
		50	3.4	57	1.5	57	1.5	52	1.4	47	1.3	42	1.1	35	0.9	26	0.7												
		60	4.2	65	1.7	65	1.7	65	1.7	62	1.7	58	1.6	50	1.3	45	1.2	38	1.0										
		75	5.2	78	2.1	78	2.1	78	2.1	78	2.1	78	2.1	74	2.0	68	1.8	32	0.9	50	1.3								
		100	6.9	99	2.7	99	2.7	99	2.7	99	2.7	99	2.7	99	2.7	99	2.7	99	2.7	99	2.7	88	2.4						
		125	8.6	122	3.3	122	3.3	122	3.3	122	3.3	122	3.3	122	3.3	122	3.3	122	3.3	122	3.3	122	3.3	122	3.3	80	2.1		
		150	10.3	143	3.8	143	3.8	143	3.8	143	3.8	143	3.8	143	3.8	143	3.8	143	3.8	143	3.8	143	3.8	143	3.8	120	3.2		
		175	12.1	160	4.3	160	4.3	160	4.3	160	4.3	160	4.3	160	4.3	160	4.3	160	4.3	160	4.3	160	4.3	160	4.3	155	4.2		
		200	13.8	180	4.8	180	4.8	180	4.8	180	4.8	180	4.8	180	4.8	180	4.8	180	4.8	180	4.8	180	4.8	180	4.8	180	4.8		
		225	15.5	205	5.5	205	5.5	205	5.5	205	5.5	205	5.5	205	5.5	205	5.5	205	5.5	205	5.5	205	5.5	205	5.5	205	5.5		
		250	17.2	220	5.9	220	5.9	220	5.9	220	5.9	220	5.9	220	5.9	220	5.9	220	5.9	220	5.9	220	5.9	220	5.9	220	5.9		
		300	20.7	265	7.1	265	7.1	265	7.1	265	7.1	265	7.1	265	7.1	265	7.1	265	7.1	265	7.1	265	7.1	265	7.1	265	7.1		
				▲ L Pilot																									
				▲ H Pilot																									
				▲ HP Pilot																									

1. When sizing a regulator, always use the lowest inlet pressure, the highest outlet pressure, and the maximum capacity desired.
 2. Requires 0.75 PSIG / 0.05 bar minimum differential pressure construction.
 - Shaded areas indicate no capacity due to differential pressure requirement.



P99 Dimensions

P99L

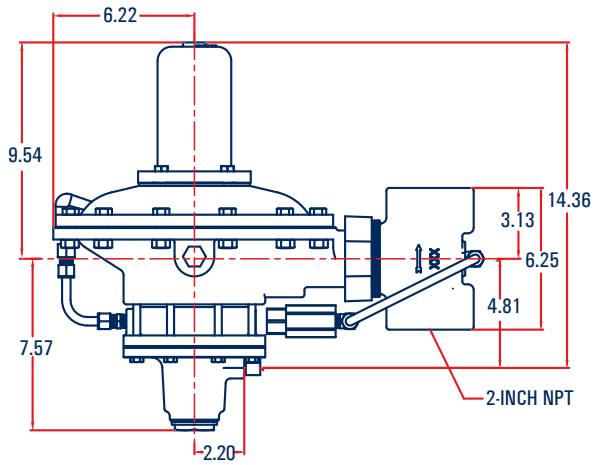

P99 Flanged with Type 61L Pilot

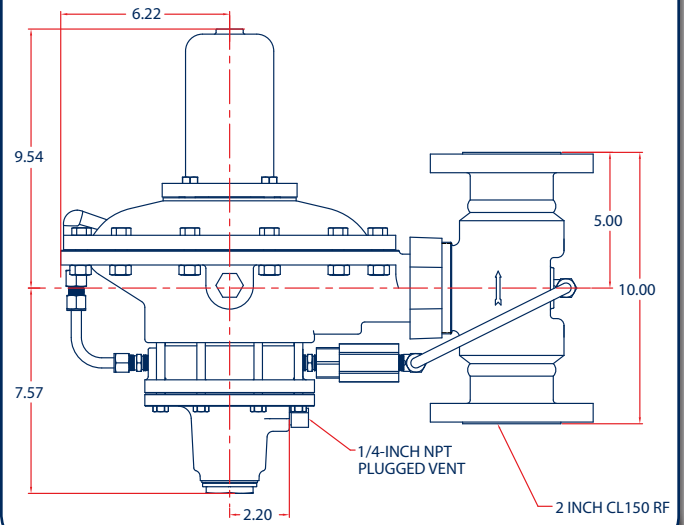

P99H

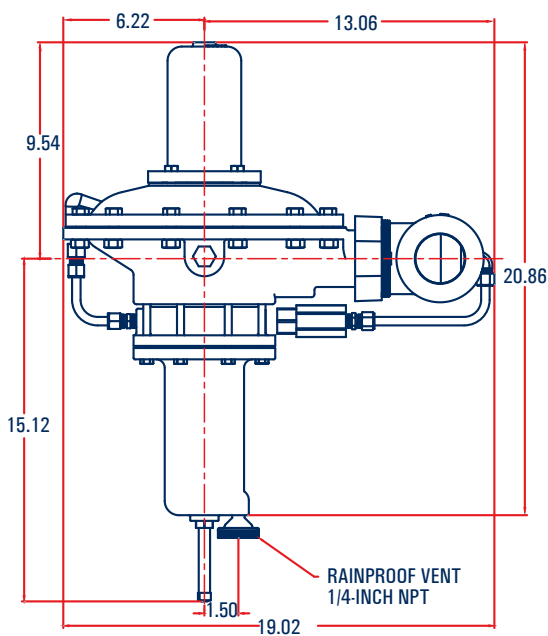
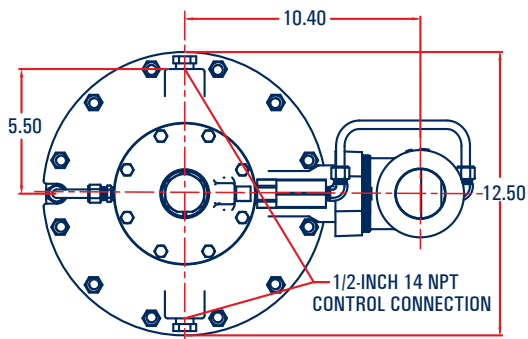

P99 HP

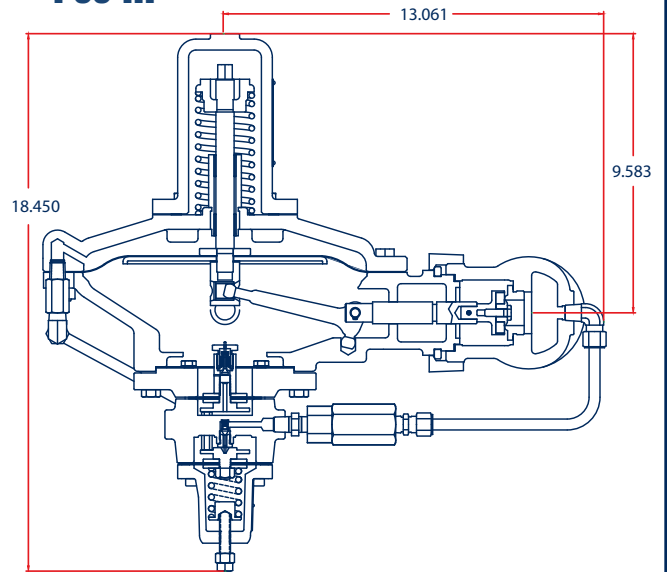

P99 HP Pilot with P39 & Relief Valve

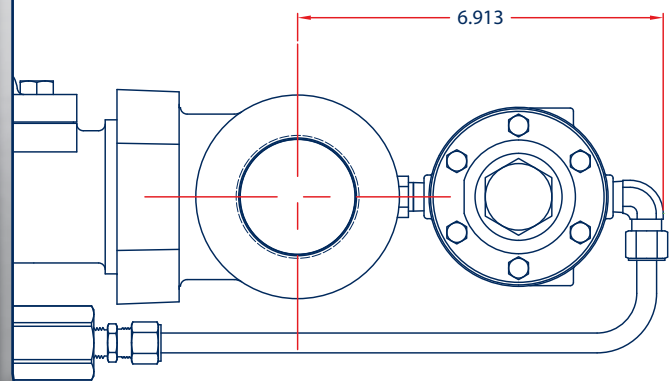

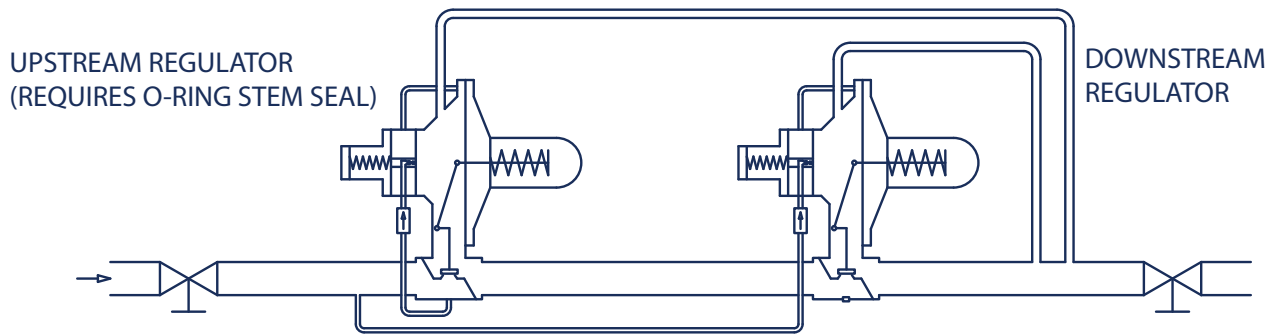

MONITOR REGULATOR MAY BE PLACED EITHER UPSTREAM OR DOWNSTREAM. REQUIRES ADDITIONAL PIPING

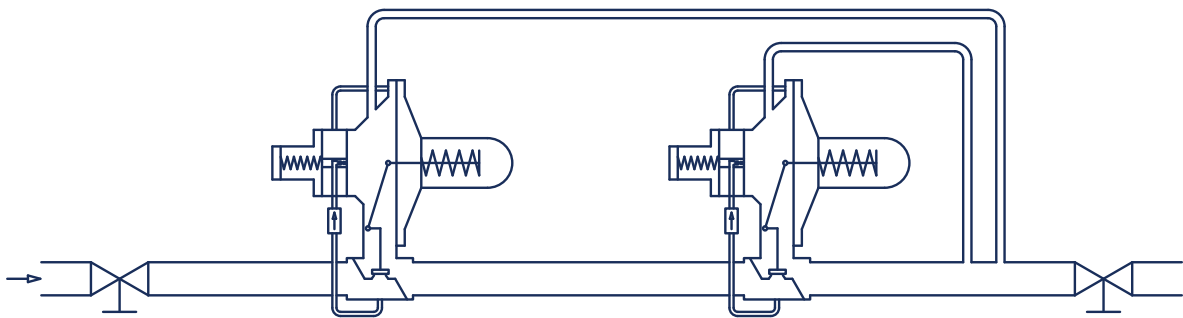

P99 WIDE-OPEN MONITOR INSTALLATIONS

Monitoring Systems

A monitor unit can serve as overpressure protection in the case of a wide-open failure of the main regulator. A P99 that is configured as a monitor regulator has a modified lower casing that includes an O-ring seal around the valve carrier.

The system should be set up as seen above with the O-ring seal unit upstream. The control line of the upstream regulator must be installed downstream of the second regulator. During normal operation, the monitor regulator remains wide open. If the main regulator fails open, the monitor regulator will take over at a slightly higher pressure.

When adjusting the set point of a wide-open monitor, first increases the set point of both regulators to a point above the desired monitor setting by turning the adjustment screws clockwise. Lower the set point of the monitor regulator to the desired pressure, and then adjust the main regulator. Be sure that the difference between the monitor and main regulator set points is at least equal to the minimum differential pressure for full stroke of the main spring.

P99 Parts with L Pilot

Item	Description	Qty.	Part Number
1	Spring Case - Cast Iron	1	604-260-000
2	Main Spring Seat	1	626-109-000
	Main Spring Seat - 1000 PSIG	1	626-109-001
3	Main Springs		
	25 PSIG Diff.	1	655-734-006
	50 PSIG Diff.	1	655-734-005
	250 PSIG Diff.	1	655-734-004
4	SS Diaphragm Rod	1	646-548-000
	Brass Diaphragm Rod Guide Assembly	1	626-111-001
5	Brass Diaphragm Rod Guide - SS	1	626-110-000
	Spring Case Gasket	1	624-081-000
7	Brass Collar	1	612-012-001
	Stainless Collar	1	612-012-000
8	Pusher Post Gasket	1	624-079-000
9	Brass Pusher Post Assembly	1	637-332-001
	Brass Pusher Post - Stainless	1	637-331-000
10	Diaphragm Plate - Steel	1	638-075-000
11	Regulator Diaphragm - Nitrile	1	618-097-000
12	Cap Screw	4	648-467-003
13	Upper Casing - Cast Iron	1	604-261-000
14	Lever - Steel	1	703-010-000
15	Casing Cap Screw	12	648-467-004
	Casing Hex Nut	12	634-199-000
17	Retaining Ring for Brass Trim	2	693-026-000
18	Lever Pin	1	635-073-000
19	Valve Carrier - Brass	1	651-102-001
	Valve Carrier - Stainless	1	651-102-000
20	Body Snap Ring	2	644-060-000
21	Union Nut	1	634-198-000
22	Body Gasket	1	624-080-000
23	Cotter Pin	1	635-000-042
25	7/8" O-ring Seat Assembly - Brass	1	822-061-0C1
	1-1/8" O-ring Seat Assembly - Brass	1	822-061-0E1
	7/8" O-ring Seat Assembly - 316	1	822-061-0C3
	1-1/8" O-ring Seat Assembly - 316	1	822-061-0E3
	7/8" Disk Seat Assembly - Brass	1	822-061-0C0
	1-1/8" Disk Seat Assembly - Brass	1	822-061-0E0
	7/8" Disk Seat Assembly - 316	1	822-061-0C2
	1-1/8" Disk Seat Assembly - 316	1	822-061-0E2
26	Brass Disk Orifice - 7/8"	1	688-057-001
	Brass Disk Orifice - 1-1/8"	1	688-058-001
	Stainless Disk Orifice - 7/8"	1	688-057-000
	Stainless Disk Orifice - 1-1/8"	1	688-058-000
	Brass O-ring Orifice - 7/8"	1	688-062-001
	Brass O-ring Orifice - 1-1/8"	1	688-063-001
	Stainless O-ring Orifice - 7/8"	1	688-062-000
	Stainless O-ring Orifice - 1-1/8"	1	688-063-000
27	2" NPT Iron	1	664-379-000
	2" NPT Steel	1	664-390-000
30	Lower Casing - Cast Iron	1	629-236-000
	Lower Casing - Monitor	1	802-124-000

Item	Description	Qty.	Part Number
31	Relay Valve Body	1	664-380-000
32	L, LE, LD Spring Case	1	604-262-000
33	Closing Cap - L, LE and LD	1	610-056-000
34	Gasket	1	624-069-000
35	L, LE and LD Screw	1	648-499-000
36	Pilot Control Springs		
	0.25 to 2 PSIG - Red	1	655-734-002
	1 to 5 PSIG - Yellow	1	655-734-007
	2 to 10 PSIG - Blue	1	655-734-003
	.5 to 15 PSIG - Brown	1	655-734-008
37	10 to 20 PSIG - Green	1	655-734-009
	L and LD Diaphragm Head	1	638-076-000
37	LE and H Diaphragm Head	1	638-077-000
	38	Upper Relay Diaphragm	1
39	Relay Yoke Assembly	1	670-035-000
40	L, LE and LD Relay Diaphragm - Nitrile	1	618-099-000
41	L, LE and LD Relay Diaphragm Head	1	638-076-001
42	L, LE and LD Spring Seat	1	650-175-000
43	Pipe Plug - (not shown)	1	639-119-000
44	Cap Screw	8	648-467-004
46	L, LE and LD Vent Assembly	1	836-004-000
47	Pilot Adjustment Screw Nut	1	634-000-056
48	Bleed Orifice - Stainless	1	688-056-000
49	Diaphragm Nut - Brass	1	634-200-001
	Diaphragm Nut - Stainless		634-200-000
50	O-ring Seal - Nitrile	1	649-309-002
51	Relay Orifice - 25 PSIG Drop	1	688-055-001
	Relay Orifice - > 25 PSIG Drop	1	688-055-000
52	L, LE and LD Bleed Valve	1	636-058-000
53	LD Bleed Valve Spring	1	655-734-010
	L and LE Bleed Valve Spring	1	655-734-000
54	Relay Disk Assembly - Nitrile	1	822-042-002
55	Elbow Fitting - Brass	1	622-061-000
56	Pilot Supply Tubing - Horizontal	1	660-081-001
	Pilot Supply Tubing - Vertical	1	660-081-002
57	Male Fitting - Brass	2	662-062-000
58	P590 Brass Line Filter - Brass	1	P590
	590 Stainless Filter	1	P594
	P590 Element - Cellulose	1	677-052-000
59	Pipe Nipple - Steel - SS	2	633-022-000
60	Loading Tubing - Copper	1	660-081-000
61	Female Fitting - Brass	1	662-063-000
62	Nameplate	1	632-546-000
63	Pilot Nameplate	1	632-547-000
64	Drive Screw	4	648-464-000

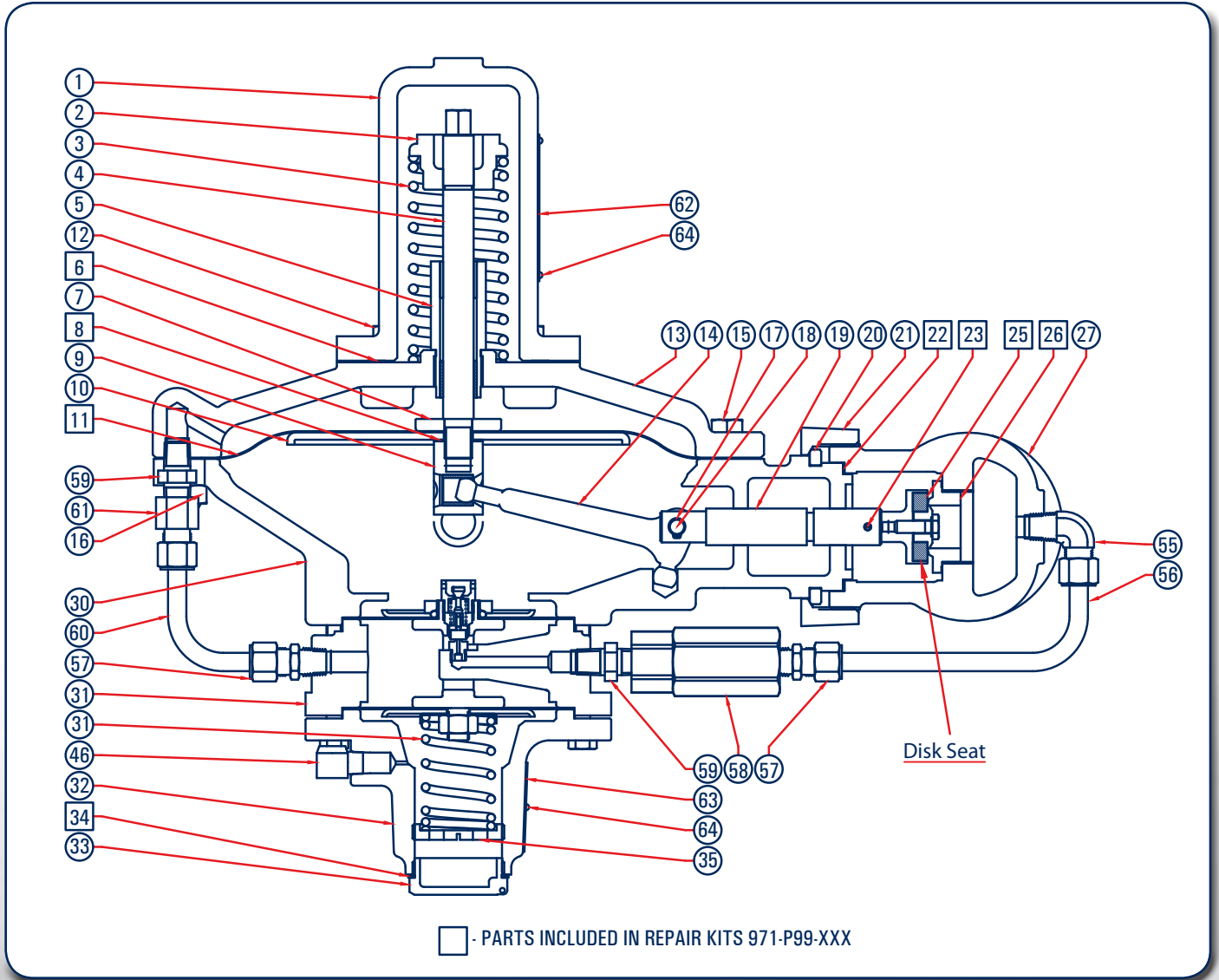

P99 Monitor Housing and O-ring Seat

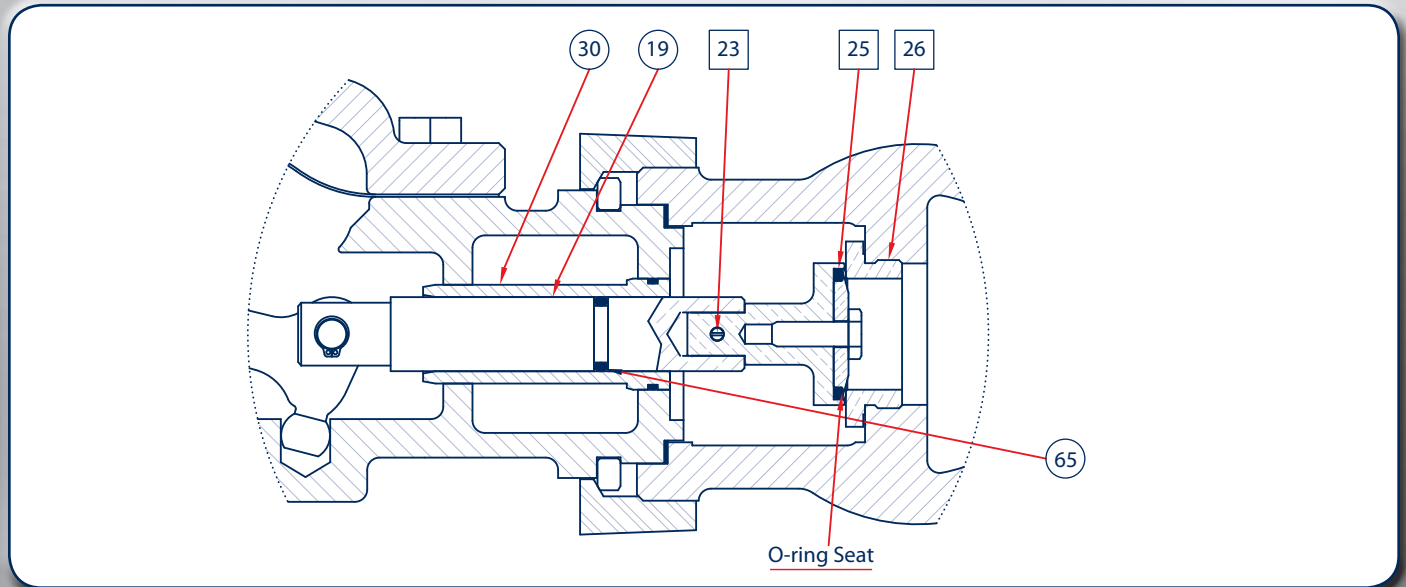

P99 Regulator with H Series Pilot Parts List

H SERIES PILOT

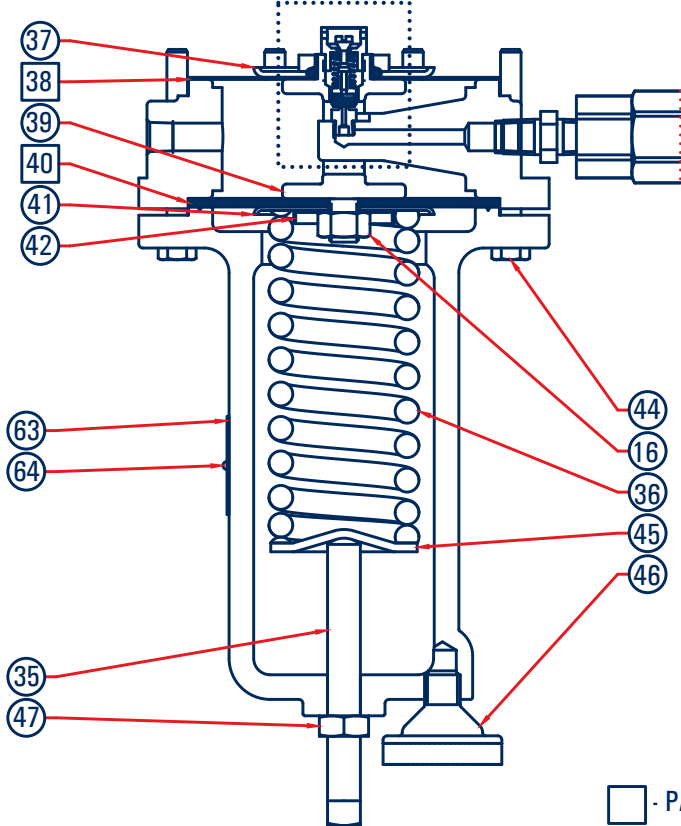

P590 SERIES FILTER

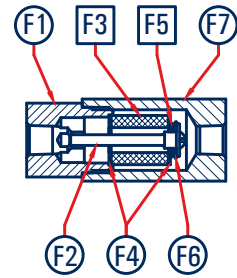

P61 SERIES BLEED VALVE ASSEMBLY

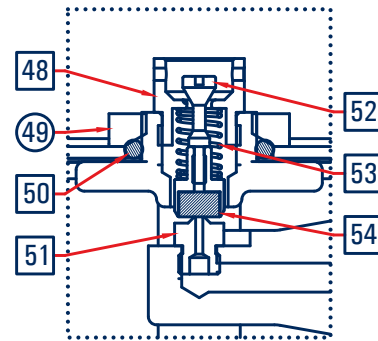

 - PARTS INCLUDED IN REPAIR KITS 971-P99-XXX

Item	Description	Qty.	Part Number
32	H Spring Case	1	604-263-000
35	H Adjustment Screw	1	648-462-000
36	10-65 psi Control Spring - Green stripe	1	655-659-003
37	H Diaphragm Head	1	638-077-000
38	Upper Relay Diaphragm	1	618-098-000
39	Relay Yoke Assembly	1	670-035-000
40	H Lower Relay Diaphragm - Nitrile	1	618-100-000
41	H Lower Relay Diaphragm Head	1	638-078-000
42	H Spring Seat	1	650-173-000
44	Cap Screw	8	648-467-004
45	Spring Seat H Only	1	626-077-000

Item	Description	Qty.	Part Number
46	H Vent Assembly	1	836-008-000
48	Bleed Orifice - Stainless	1	688-056-000
49	Diaphragm Nut - Brass	1	634-200-001
	Diaphragm Nut - Stainless	1	634-200-000
50	O-ring Seal - Nitrile	1	649-309-002
51	Relay Orifice - 25 PSIG Drop	1	688-055-001
	Relay Orifice - > 25 PSIG Drop	1	688-055-000
52	H Bleed Valve	1	636-058-001
53	H Bleed Valve Spring	1	655-734-001
54	Relay Disk Assembly - Nitrile	1	822-042-002

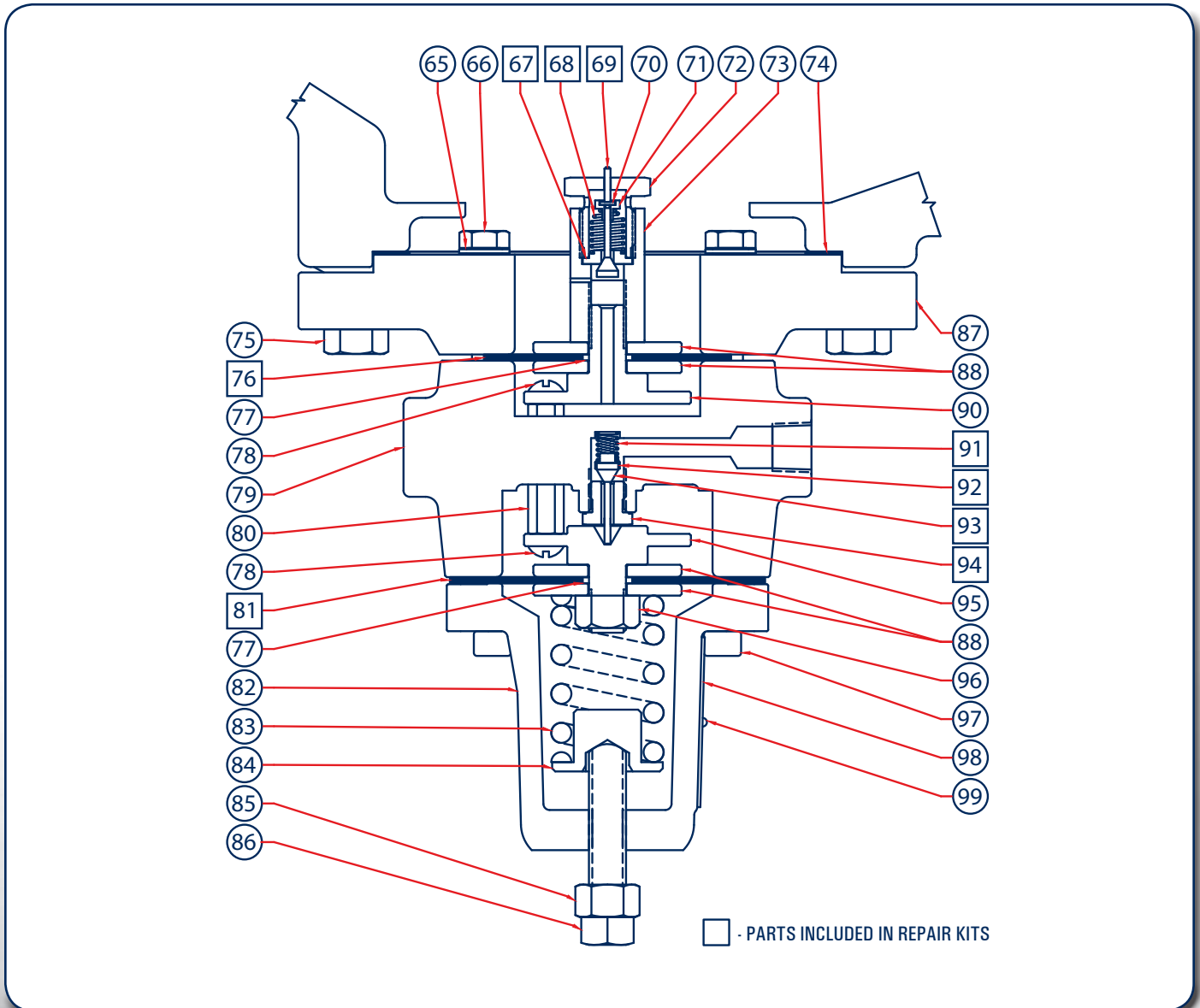

Item	Description	Qty.	Part Number
65	Seal Washer	2	662-239-000
66	Build Screw	2	648-567-000
67	Bleed Valve Orifice	1	688-065-000U
68	Bleed Valve Spring	1	655-734-013
69	Bleed Valve	1	636-060-000
70	Spring Seat Washer	1	693-032-000
71	Spring Seat	1	643-221-000
72	Relief Valve Cap	1	610-093-000
73	Relief Valve Body	1	664-574-000
74	Flange Adaptor Gasket	1	624-098-000
75	Build Screw	2	648-567-002
76	Upper Diaphragm	1	618-106-000
77	Diaphragm Insert	2	624-097-000
78	Slotted Round Screw	2	648-568-000
79	Pilot Body	1	664-573-000
80	Yoke Standoff	1	654-193-000
81	Lower Diaphragm	1	618-107-000
82	Pilot Bonnet	1	604-563-000

Item	Description	Qty.	Part Number
83	Main Spring 35-100	1	655-734-012
84	Main Spring Seat	1	650-191-000
85	Jam Nut	1	634-475-000
86	Adjustment Screw	1	648-566-000
87	Pilot Flange Adaptor	1	623-047-000
88	Diaphragm Plate	4	638-085-000
90	Upper Yoke Cap	1	610-092-001
91	Pintle Spring	1	655-734-014
92	Pintle Spring Seat	1	650-190-000
93	Molded Pintle Assy	1	813-054-000
94	Pilot Orifice	1	688-064-000
95	Lower Yoke Cap	1	610-092-000
96	Diaphragm Nut	1	634-476-000
97	Build Screw	2	648-567-001
98	Nameplate	1	632-570-000
	Pilot Tube Adaptor	1	622-072-001
Not Shown	Loading Tubing	1	660-117-000
	Pilot Tubing	1	660-117-001